



## User Manual



## ULTRA-G GI100

Professional Battery/Phantom Powered DI-Box with  
Guitar Speaker Emulation

**МУЗЦЕНТР**  
МУЗЫКАЛЬНОЕ ОБОРУДОВАНИЕ

<https://muzcentre.ru>

**EN Table of Contents**

<b>Thank you .....</b>	<b>2</b>
<b>Important Safety Instructions .....</b>	<b>3</b>
<b>Legal Disclaimer .....</b>	<b>4</b>
<b>Limited Warranty .....</b>	<b>5</b>
<b>1. Controls .....</b>	<b>10</b>
<b>2. Connection examples .....</b>	<b>12</b>
2.1 Conversion of guitar signals .....	12
2.2 Picking up a bass guitar or keyboard signal .....	13
2.3 Converting a microphone signal from high-impedance unbalanced to low-impedance balanced.....	14
2.4 Picking up a signal from a loudspeaker output .....	14
<b>3. Specifications.....</b>	<b>15</b>

**Thank you**

Thank you for showing your confidence in us by purchasing the ULTRA-GI GI100.

## EN Important Safety Instructions



 Terminals marked with this symbol carry electrical current of sufficient magnitude to constitute risk of electric shock. Use only high-quality professional speaker cables with ¼" TS or twist-locking plugs pre-installed. All other installation or modification should be performed only by qualified personnel.

 This symbol, wherever it appears, alerts you to the presence of uninsulated dangerous voltage inside the enclosure - voltage that may be sufficient to constitute a risk of shock.

 This symbol, wherever it appears, alerts you to important operating and maintenance instructions in the accompanying literature. Please read the manual.

 **Caution**  
To reduce the risk of electric shock, do not remove the top cover (or the rear section). No user serviceable parts inside. Refer servicing to qualified personnel.



### Caution

To reduce the risk of fire or electric shock, do not expose this appliance to rain and moisture. The apparatus shall not be exposed to dripping or splashing liquids and no objects filled with liquids, such as vases, shall be placed on the apparatus.



### Caution

These service instructions are for use by qualified service personnel only. To reduce the risk of electric shock do not perform any servicing other than that contained in the operation instructions. Repairs have to be performed by qualified service personnel.

Read these instructions.

1. Keep these instructions.
2. Heed all warnings.
3. Follow all instructions.
4. Do not use this apparatus near water.
5. Clean only with dry cloth.
6. Do not block any ventilation openings. Install in accordance with the manufacturer's instructions.
7. Do not install near any heat sources such as radiators, heat registers, stoves, or other apparatus (including amplifiers) that produce heat.
8. Do not defeat the safety purpose of the polarized or grounding-type plug. A polarized plug has two blades with one wider than the

EN

other. A grounding-type plug has two blades and a third grounding prong. The wide blade or the third prong are provided for your safety. If the provided plug does not fit into your outlet, consult an electrician for replacement of the obsolete outlet.

**9.** Protect the power cord from being walked on or pinched particularly at plugs, convenience receptacles, and the point where they exit from the apparatus.

**10.** Use only attachments/accessories specified by the manufacturer.



**11.** Use only with the cart, stand, tripod, bracket, or table specified by the manufacturer, or sold with the apparatus.

When a cart is used, use caution when moving the cart/apparatus combination to avoid injury from tip-over.

**12.** Unplug this apparatus during lightning storms or when unused for long periods of time.

**13.** Refer all servicing to qualified service personnel. Servicing is required when the apparatus has been damaged in any way, such as power supply cord or plug is damaged, liquid has been spilled or objects have fallen into the apparatus, the apparatus has been exposed to rain or moisture, does not operate normally, or has been dropped.

**14.** The apparatus shall be connected to a MAINS socket outlet with a protective earthing connection.

**15.** Where the MAINS plug or an appliance coupler is used as the disconnect device, the disconnect device shall remain readily operable.



---

## LEGAL DISCLAIMER

TECHNICAL SPECIFICATIONS AND APPEARANCES ARE SUBJECT TO CHANGE WITHOUT NOTICE AND ACCURACY IS NOT GUARANTEED. BEHRINGER, KLARK TEKNIK, MIDAS, BUGERA, AND TURBOSOUND ARE PART OF THE MUSIC GROUP (MUSIC-GROUP.COM). ALL TRADEMARKS ARE THE PROPERTY OF THEIR RESPECTIVE OWNERS. MUSIC GROUP ACCEPTS NO LIABILITY FOR ANY LOSS WHICH MAY BE SUFFERED BY ANY PERSON WHO RELIES EITHER WHOLLY OR IN PART UPON ANY DESCRIPTION, PHOTOGRAPH OR STATEMENT CONTAINED HEREIN. COLORS AND SPECIFICATIONS MAY VARY FROM ACTUAL PRODUCT. MUSIC GROUP PRODUCTS ARE SOLD THROUGH AUTHORIZED FULLFILLERS AND RESELLERS ONLY. FULLFILLERS AND RESELLERS ARE NOT AGENTS OF MUSIC GROUP AND HAVE

ABSOLUTELY NO AUTHORITY TO BIND MUSIC GROUP BY ANY EXPRESS OR IMPLIED UNDERTAKING OR REPRESENTATION. THIS MANUAL IS COPYRIGHTED. NO PART OF THIS MANUAL MAY BE REPRODUCED OR TRANSMITTED IN ANY FORM OR BY ANY MEANS, ELECTRONIC OR MECHANICAL, INCLUDING PHOTOCOPYING AND RECORDING OF ANY KIND, FOR ANY PURPOSE, WITHOUT THE EXPRESS WRITTEN PERMISSION OF MUSIC GROUP IP LTD.

ALL RIGHTS RESERVED.

© 2013 MUSIC Group IP Ltd.

Trident Chambers, Wickhams Cay,  
P.O. Box 146, Road Town, Tortola,  
British Virgin Islands

---

## LIMITED WARRANTY

For the applicable warranty terms and conditions and additional information regarding MUSIC Group's Limited Warranty, please see complete details online at [www.music-group.com/warranty](http://www.music-group.com/warranty).

**EN Welcome to BEHRINGER!**

In addition to the numerous advantages of an excellent DI box, the GI100 features an extremely authentic, pure analog simulation of a 4 x 12" guitar speaker cabinet.

On stage and in the studio, it is often desirable to directly connect sound sources with the console. Although this method has many advantages, it also has its technical hurdles. Keyboards rarely offer balanced outputs, and it's simply not possible to connect electric guitars or basses directly to a console. Although common practice, placing a microphone in front of the speaker cabinet is not really an ideal solution, since the mic tends to pick up signals from other instruments and creates another potential source of feedback.

A DI (Direct Injection) box allows you to pick up a signal **directly** from an unbalanced, high impedance output, like that of an electric guitar, and **inject** it into the console, without using a microphone. There are of course several situations that call for feeding an unbalanced sound source directly into a console—preferably in a balanced form. That's exactly what a DI box is for.

Basically, there are two types of DI boxes: passive and active. A passive DI box contains much simpler circuitry and requires no batteries, making it is less expensive. On the other hand, its performance is dependent on the impedance of the connected gear. A change in impedance on the output side will cause the input impedance to change. Among other things, the impedance ratings greatly effect the frequency response. A passive DI box only works correctly when impedance specifications are adhered to (in short: high-Z input, low-Z output).

Active DI boxes, which use an amplifier to buffer the input signal, are not subject to these limitations. The ULTRA-G's input impedance is extremely high, so it lets the input signal pass through with virtually no coloring. At the other end, its balanced output has a particularly low impedance, making the signal much less susceptible to hum and noise. The GI100 is an active DI box and performs optimally regardless of the impedance ratings of the connected gear.

The ULTRA-G is based on the proven BEHRINGER OT-1 transformer, which ensures crystal-clear, distortion-free sound and a wide, linear frequency response. In addition, it can be powered by the console's phantom power or by an internal battery. The battery is automatically "disconnected" when phantom power is present to preserve battery life.

- ◆ **In order to avoid damage to your loudspeakers, always mute the corresponding channel on the consoles before connecting the GI100. The same applies when switching between phantom and battery power.**

The GI100 features a switchable speaker simulation, developed in collaboration with renowned amp designer Jürgen Rath, which adds the sound of a 4 x 12" cabinet to your direct guitar signal at the touch of a button. Analog speaker simulations, offering the possibility to get a typical guitar cabinet sound to tape or to a PA without the necessity of cabinets or microphones, have been available since the mid-80's. Since then, the appeal of "instant sound" via simulation as a means of reducing equipment and hassle has continuously grown. Having developed a great deal of convincing guitar gear with various manufacturers, Jürgen Rath was an obvious choice for us in developing our VIRTUAL 4 x 12" CABINET speaker simulation. In the words of Germany's top specialty publication GITARRE & BASS, "The Virtual Cabinet delivers an authentic 4 x 12" simulation with impressive sound, cutting power and clear reproduction." (Michael Dommers, 8/97)

## 1. Controls

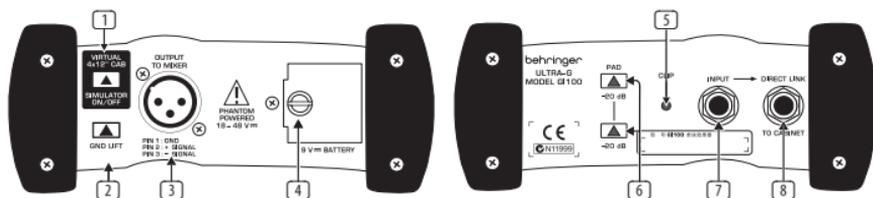

Fig. 1.1: The GI100's front and back panels

- 1 The VIRTUAL 4 x 12" CAB speaker simulation can be switched on and off with the **SIMULATOR ON/OFF** switch.
  - 2 When activated, the **GND LIFT** breaks the ground connection between input and output. Depending on the grounding of the connected equipment, this can eliminate hum or ground loops.
  - 3 **OUTPUT TO MIXER** is the GI100's balanced, mic level output. Use a high-quality, balanced XLR (microphone) cable to connect the ULTRA-G to a console.
- ♦ You should never connect pins 2 or 3 with pin 1 or remove the shield from pin 1. Otherwise, it will not be possible to operate the unit with phantom power.

- EN** 4 **BATTERY COMPARTMENT.** To install or replace the 9 V battery, remove the screw and lift the lid.
- 5 The **CLIP** LED lights up when the input signal level is too high.
- 6 The two **-20 dB PAD** switches noticeably increase the operating range of the ULTRA-G, allowing it to accept anything from the low-level signal of a high-impedance microphone or guitar to the loudspeaker output of a guitar amp. These switches have repeatedly proven themselves in the BEHRINGER ULTRA-DI DI100. Pressing both switches results in a gain reduction of 40 dB.
- ◆ **Before using the PAD switches, be sure that the ULTRA-G is clipping, and not the mic preamp on the console. You should only attenuate the input signal via the GI100's PAD switches if its CLIP LED lights up frequently or remains lit. If this is not the case and distortion occurs, check the console settings. It is always best to avoid attenuation of the DI input to ensure an optimal signal-to-noise ratio.**
- 7 **INPUT.** Use this ¼" mono jack to connect the signal source, e.g. your guitar, with a high-quality standard instrument cable.
- ◆ **The GI100 is switched on as soon as you insert a plug into the INPUT. The battery is "disconnected" when the plug is removed. For this reason, the GI100 has no on/off switch. To preserve battery life, always disconnect the input when the ULTRA-G is not in use.**
- 8 The **DIRECT LINK TO CABINET** is a direct output of the input signal, allowing you for example to simultaneously run your instrument through the GI100 and complete your normal signal path by connecting the DIRECT LINK to an amp or speaker cabinet.
- ◆ **The Input and DIRECT LINK sockets are directly connected. When connecting the speaker output of a tube amp to the input of the GI100, please be sure to connect a guitar speaker or other appropriate impedance load to the DIRECT LINK socket in order to avoid possible damage to your amplifier.**

## 2. Connection examples

The following section illustrates various applications of the ULTRA-G GI100.

### 2.1 Conversion of guitar signals

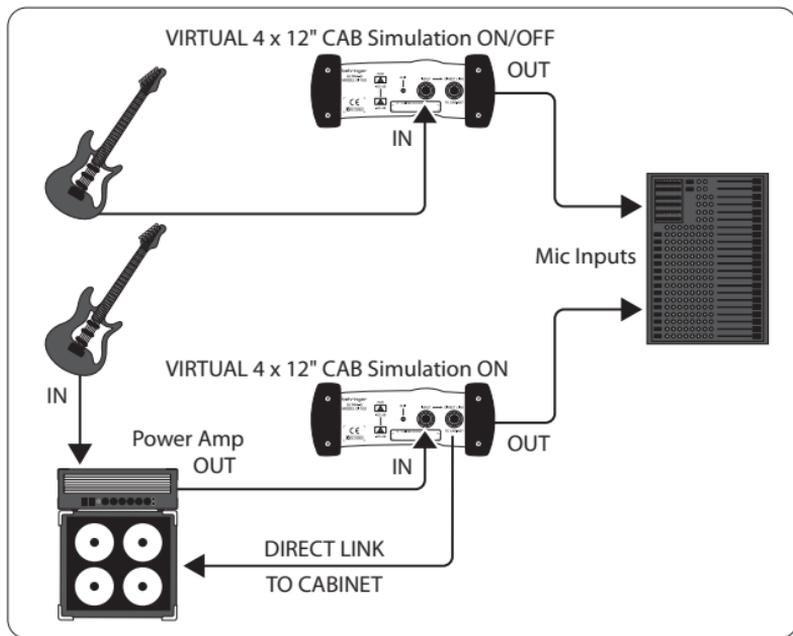

Fig. 2.1: 1. Guitar → GI100 → Console  
2. Guitar → Tube amplifier → GI100 → Loudspeaker/Console

This diagram illustrates two common applications in which unbalanced guitar signals are converted into balanced signals. In the first example the guitar is connected directly to the GI100, which in turn feeds the console. No guitar amp is used. In this case, the PAD switches should be deactivated with the VIRTUAL CAB switched on or off depending on the sound desired.

The second example shows the GI100 being driven by the loudspeaker output of a guitar amp. If you're using a tube amp, it's very important to connect an impedance load—preferably a speaker—to the DIRECT LINK TO CABINET output in order to prevent damage to your amp. For this application, start with one PAD switch depressed and the GND LIFT switch activated. We also recommend using the VIRTUAL CAB speaker simulation for an authentic guitar sound.

## EN 2.2 Picking up a bass guitar or keyboard signal

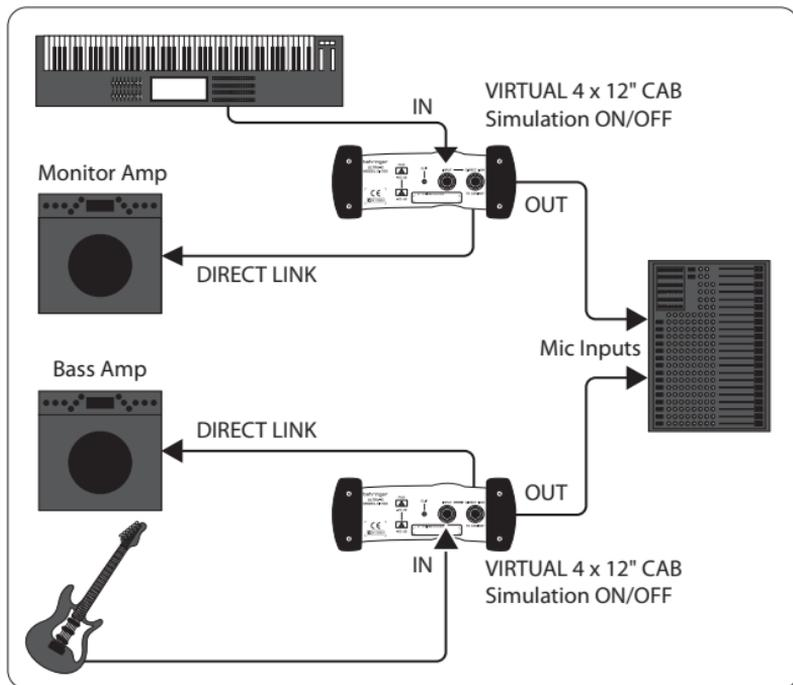

Fig. 2.2: 1. Bass guitar → GI100 → Amplifier/Console  
2. Keyboard → GI100 → Amplifier/Console

This diagram illustrates two standard DI applications. The signal going to the amp via the DIRECT LINK is unaffected; it is simply picked up and additionally fed, as a balanced, low-impedance signal, to the mic inputs of the mixing console. This is particularly advantageous with bass guitars, since microphones that reproduce high-energy bass frequencies in a halfway linear manner are rare—and expensive. When using effects or other outboard processors, these should be connected in front of the ULTRA-G in the signal path, so that its output includes these signals.

Few keyboards have balanced outputs. Here, a quality DI box such as the GI100 is indispensable to ensure clean signals, especially when using long cables.

## 2.3 Converting a microphone signal from high-impedance unbalanced to low-impedance balanced

Many inexpensive microphones have unbalanced high-impedance outputs. With the ULTRA-G, these microphones can be used in spite of long cable runs without the danger of hum or other interference. Simply insert the GI100 between the microphone and the console. For this application, you will most likely want to switch the VIRTUAL CAB speaker simulation off.

## 2.4 Picking up a signal from a loudspeaker output

There are times when picking up a signal after amplifier processing is desirable to achieve a certain sound, but no direct out is available. Thanks to the GI100's two -20 dB PAD switches, you can feed a console from the loudspeaker output of an amplifier with a power rating of up to 3,000 Watts (4 Ohm) without overloading the ULTRA-G. When using a tube amp, be sure to connect a speaker or other impedance load to the DIRECT LINK output. We recommend using the VIRTUAL CAB speaker simulation in these applications, when signals from electric guitars are transmitted.

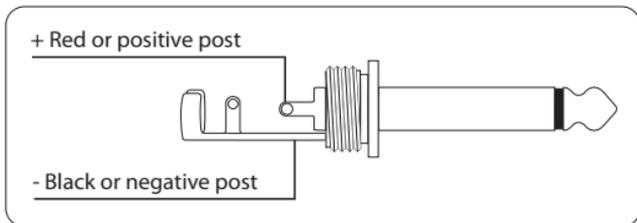

Fig. 2.3: Connection to an amplifier's output

- ◆ Before connection to a loudspeaker output, always make sure that the GND LIFT switch is activated (depressed) to prevent accidental short-circuiting of the amplifier output. The metal casing of the GI100 should not have direct contact with other equipment. The tip of the output socket should be connected to the positive (red) loudspeaker pole.

**EN 3. Specifications**

Frequency response	10 Hz to 160 kHz
Noise	-99.2 dBu
Distortion	< 0.014% (1 kHz, 0 dBu in)
Input resistance	> 250 kOhm
Connection impedance	> 600 Ohm
Input	¼" mono jack
Output	XLR balanced
Max. input level	+8/ +28/ +48 dBu (Simulation OFF) -2/ +18/ +38 dBu (Simulation ON)

**Supply:**

Phantom supply	18 V DC to 48 V DC
Battery	9 V 6LR91
Dimensions	150 x 130 x 60 mm (6 x 5 x 2.4")
Weight	approx. 650 g

BEHRINGER is constantly striving to maintain the highest professional standards. As a result of these efforts, modifications may be made from time to time to existing products without prior notice. Specifications and appearance may therefore differ from those listed or shown.



We Hear You